

GAMESA G87-2.0 MW

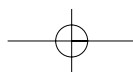

Gamesa



BENEFITS

**Maximum output
at minimum cost
per kWh for medium
wind sites**

- **Class IIA/WZII.**
- **Pitch and variable speed technology to maximize energy production.**
- **Production of lighter blades using fiberglass, carbon fiber and prepreg method.**
- **Compliance with the main international Grid Codes.**
- **Aerodynamic design and Gamesa NRS™ control system to minimize noise emissions.**
- **Gamesa SGIPE: Remote monitoring and control system with Web access.**

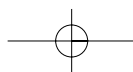
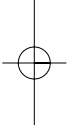
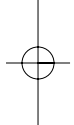
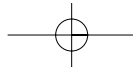

Rotor

Diameter	87 m
Swept area	5.945 m ²
Rotational speed	9,0 - 19,0 rpm
Rotational direction	Clock Wise (front view)
Weight (incl. Hub)	Approx. 37 T
Top head mass	Approx. 107 T

Blades

Number of blades	3
Length	42,5 m
Airfoils	DU (Delft University) + FFA-W3
Material	Preimpregnated epoxy glass fiber + carbon fiber
Total blade weight	6.150 kg

Tubular Tower

Modular type	Height	Weight
3 sections	67 m	153 T
4 sections	78 m	203 T
5 sections	100 m	242 T

Gearbox

Type	1 planetary stage / 2 helical stages
Ratio	50 Hz 1:100,5 60 Hz 1:120,5
Cooling	Oil pump with oil cooler
Oil heater	2,2 kW

Generator 2.0 MW

Type	Doubly- fed machine
Rated power	2,0 MW
Voltage	690 V ac
Frequency	50 Hz / 60 Hz
Protection class	IP 54
Number of poles	4
Rotational speed	900:1.900 rpm (rated 1.680 rpm)
Rated Stator Current	1.500 A @ 690 V
Power factor (standard)	0,98 CAP - 0,96 IND at partial loads and 1 at nominal power. *
Power factor (optional)	0,95 CAP - 0,95 IND throughout the power range. *

* Power factor at generator output terminals, at low voltage side before transformer input terminals.

Mechanical design

Drive train with main shaft supported by two spherical bearings that transmit the side loads directly to the frame by means of the bearing housing. This prevents the gearbox from receiving additional loads, reducing malfunctions and facilitating its service.

Brake

Aerodynamic primary brake by means of full-feathering blades. In addition, a hydraulically-activated mechanical disc brake for emergencies is mounted on the gearbox high speed shaft.

Lightning protection

The Gamesa G87-2.0 MW wind turbine generator uses the "total lightning protection" system, in accordance with standard IEC 61024-1. This system conducts the lightning from both sides of the blade tip down to the root joint and from there across the nacelle and tower structure to the grounding system located in the foundations. As a result, the blade and sensitive electrical components are protected from damage.

Control System

- The Generator is a doubly fed machine (DFM), whose speed and power is controlled through IGBT converters and PWM (Pulse Width Modulation) electronic control.
- Benefits:
 - Active and reactive power control.
 - Low harmonic content and minimal losses.
 - Increased efficiency and production.
 - Prolonged working life of the turbine.

Gamesa SGIPE

Wind farm control system, developed by Gamesa, that allows real-time operation and remote control of wind turbines, meteorological mast and electrical substation via satellite-terrestrial network. Modular design with control tools for active and reactive energy, noise, shadows and wake effects. TCP/IP architecture with a Web interface.

SMP-8C Predictive Maintenance System

Predictive Maintenance System for the early detection of potential deterioration or malfunctions in the wind turbine's main components.

- Benefits:
 - Reduction in major corrective measures.
 - Increase in the machine's availability and working life.
 - Preferential terms in negotiations with insurance companies.
 - Integration within the control system.

Noise control

Aerodynamic blade tip and mechanical component design minimize noise emissions. In addition, Gamesa has developed the Gamesa NRS™ noise control system, which permits programming the noise emissions according to criteria such as date, time or wind direction. This achieves the goals of local regulation compliance as well as maximum production.

Low noise curves: 104, 103, 102, 101 dB.

Grid connection

Gamesa's doubly-fed wind turbines and Active Crowbar and over sized converter technologies ensure the compliance with the most demanding grid connection requirements.

Low voltage ride-through capability and dynamic regulation of active and reactive power.

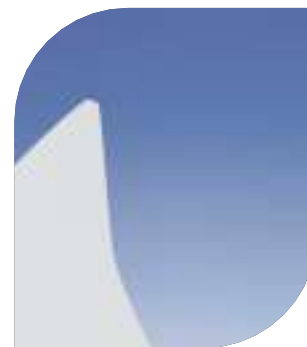
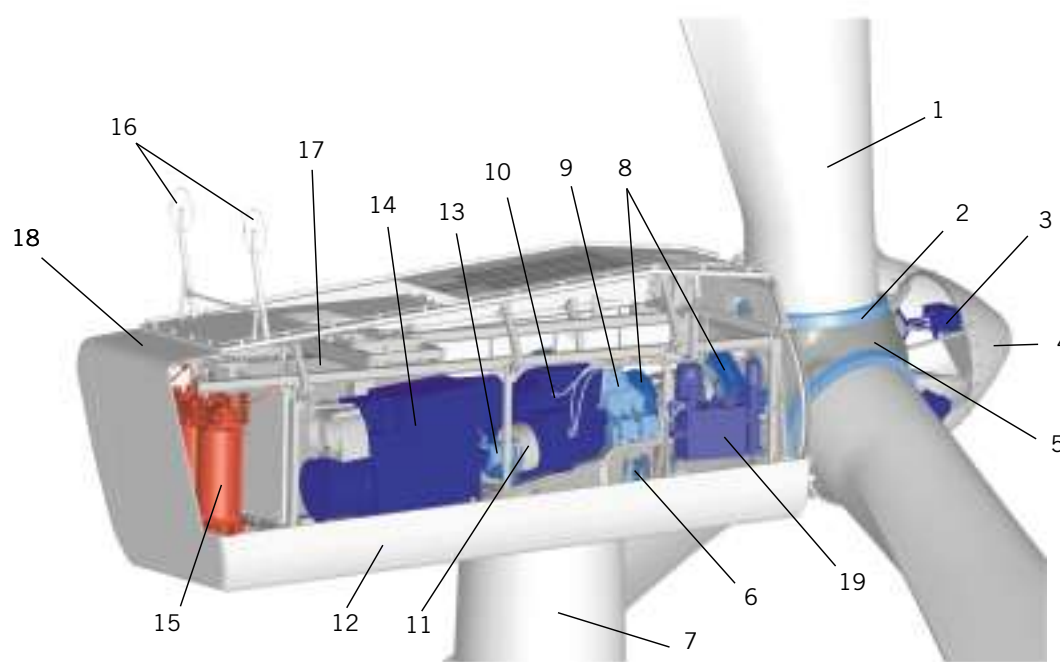

- 1. Blade
- 2. Blade bearing
- 3. Hydraulic pitch actuator
- 4. Hub cover
- 5. Hub

- 6. Active yaw control
- 7. Tower
- 8. Main shaft with two bearing houses
- 9. Shock absorbers

- 10. Gearbox
- 11. Main disc brake
- 12. Nacelle support frame
- 13. Transmission: High speed shaft
- 14. Doubly fed generator

- 15. Transformer
- 16. Anemometer and wind vane
- 17. Top controller
- 18. Nacelle cover
- 19. Hydraulic unit

Power Curve Gamesa G87-2.0 MW (for an air density of 1,225 kg/m³)

Power curve calculation based on DU (Delft University) and FFAW3 airfoils.

Calculation parameters: 50 Hz grid frequency; tip angle pitch regulated; 10% turbulence intensity and a variable rotor speed ranging from 9,0-19,0 rpm.

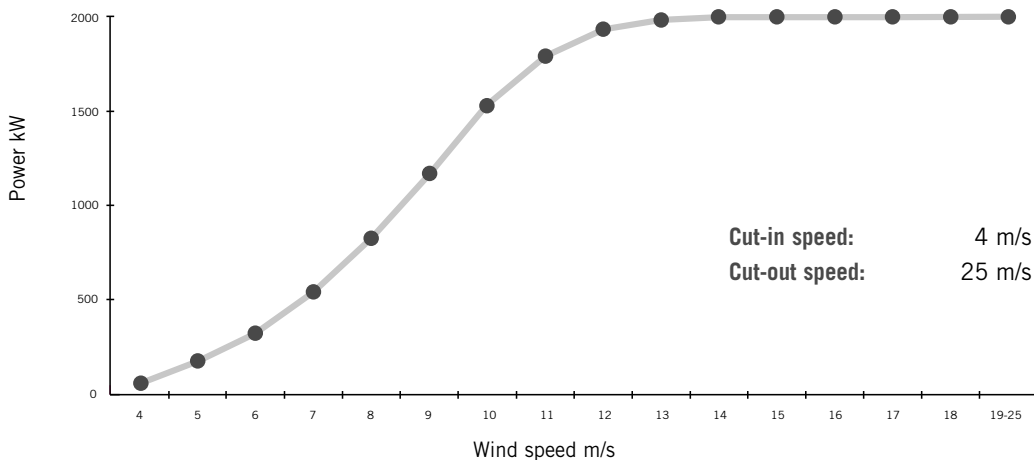

Speed (m/s)	Power (kW)
4	78,6
5	181,2
6	335,4
7	549,8
8	831,5
9	1174,8
10	1528,3
11	1794,7
12	1931,1
13	1981,0
14	1995,3
15	1998,9
16	1999,8
17	2000,0
18	2000,0
19-25	2000,0

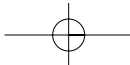

Polígono Industrial Agustinos, C/A s/n
31013 Pamplona, Spain
Tel: +34 948 309010
Fax: +34 948 309009
info@eolica.gamesa.es
www.gamesa.es

Gamesa Wind GmbH

Wailandtstrasse 7
63741 Aschaffenburg
Germany
Tel: +49 (0) 6021 15 09 0
Fax: +49 (0) 6021 15 09 199
E-mail: info@wind.gamesa.de

Gamesa Wind Engineering

Vejlsøvej 51
8600 Silkeborg
Denmark
Tel: +45 87 229205 / 9204
Fax: +45 87 229201

France

Parc Mail
6 Allée Joliot Curie, bâtiment B
69791 Saint Priest
Tel: +33 (0) 472 79 47 09
Fax: +33 (0) 478 90 05 41

Greece

3, Pampouki Street
154 51 Neo Psychiko
Athens
Tel: +30 21 06753300
Fax: +30 21 06753305

Gamesa Eolica Italia

Via Pio Emanuelli,1
Corpo B, 2° piano
00143 Rome
Tel: +39 0651531036
Fax: +39 0651530911

Portugal

Edifício D. João II
PARQUE DAS NAÇÕES
Av. D. João II, lote 1.06.2.3-7° B
1990-090 Lisbon
Tel: +351 21 898 92 00
Fax: +351 21 898 92 99

United Kingdom

Rowan House Hazell Drive
NEWPORT South Wales NP10 8FY
Tel: +44 1633 654 140
Fax: +44 1633 654 147

Gamesa Wind US

1 Ben Fairless Drive - Ste. 2
Fairless Hills, PA 19030
Tel: +1 215 736 8165
Fax: +1 215 736 3985

Gamesa Wind Tianjin

Room 1105, Tower 1,
Bright China
Changan Building
7 Jianguomennei
Av. Beijing 100005
China
Tel.: +86 10 65186158
Fax: +86 10 65180256



The specifications listed in this brochure may be subject to revision without prior notice.
The specifications listed are not contractually binding.
Printed: December 2006

